

Patent Law
Spring 2016
Prof. Ford

Obviousness claim-chart exercise

A claim chart is a tool for demonstrating which limitations of a patent claim are present in another work. For instance, an invalidity claim chart shows how each limitation is present (or not) in the prior art; likewise, an infringement claim chart shows how each limitation is present (or not) in the defendant's accused product. The claim chart demonstrates this by quoting and citing portions of the work that embody or disclose a claim limitation, or by citing or reproducing figures or graphics embodying or disclosing that claim limitation.

In this exercise, you will assemble an obviousness claim chart for claim 1 of U.S. Patent No. 5,026,109 (the '109 patent), which claims a tarp system for covering a truck trailer. You represent the accused infringer, who asserts that the claim is an obvious combination of two prior-art references: U.S. Patent Nos. 4,189,178 (Cramaro) and 3,415,260 (Hall).

For this exercise, I have provided copies of each patent and a Microsoft Word template for your claim chart. Read the '109 patent and the Cramaro and Hall references. For each limitation of claim 1 of the '109 patent and each prior-art reference, provide one or more quotes, cites, or figures from the reference demonstrating that the limitation is disclosed by that reference — if it is. (Since this is an obviousness argument, not an anticipation argument, not every limitation will be present in each reference.) I have filled out two sample entries in the claim chart. Please cite each quote with the column and line numbers, as I have done, or by figure number or section of the front matter (title, abstract, and so forth). You may also wish to refer to online copies of the patents, such as the Google Patents versions here: ['109 patent](#); [Cramaro](#); [Hall](#).

This exercise is due on Friday, March 27 at 6:00 pm. Please email your completed responses by then to roger.ford@law.unh.edu. You may complete this exercise individually or in a group of up to four students, so long as you each contribute substantially to the completed claim chart. If you work in a group, please provide the names of all group members on your completed claim chart.

[54] SEGMENTED COVER SYSTEM

[75] Inventor: Vincent J. Merlot, Jr., Oakmont, Pa.

[73] Assignee: Sundance, Inc., Pittsburgh, Pa.

[21] Appl. No.: 414,193

[22] Filed: Sep. 28, 1989

[51] Int. Cl.⁵ B60D 25/06

[52] U.S. Cl. 296/105; 296/118; 160/84.1

[58] Field of Search 296/100, 98, 104, 105, 296/118; 160/84.1, 392, 395

[56] References Cited

U.S. PATENT DOCUMENTS

2,469,958	5/1949	Fowler	296/105
2,950,727	8/1960	Dunn	160/392 X
3,720,438	3/1973	Johnson et al.	296/163
3,875,623	8/1975	Johnston	160/392 X
3,979,782	9/1976	Lamb	296/100 X
4,189,178	2/1980	Cramaro	296/100 X
4,328,853	5/1982	Gall et al.	160/84.1 X
4,747,441	5/1988	Apolzer et al.	296/100 X
4,801,171	1/1989	Weaver	296/105X
4,854,630	8/1989	Biancale	296/100

FOREIGN PATENT DOCUMENTS

2519365 11/1976 Fed. Rep. of Germany 160/392

Primary Examiner—Margaret A. Focarino

Assistant Examiner—Joseph D. Pape

Attorney, Agent, or Firm—Reed Smith Shaw & McClay

[57] ABSTRACT

The present invention provides a segmented cover system utilizing a series of cover sections, which can be of any size and shape, and a series of curved or straight supporting bows to form a cover assembly which allows for the easy replacement of a cover section or a bow without disassembling the entire cover system. The present cover assembly preferably utilizes a series of standard cover sections which are detachably secured to the two adjacent supporting bows. Preferably, the supporting bows are curved and consist of a bow center section and two easily removable bow end sections. The unique design, construction and interaction of the cover sections, the bow center sections and the bow ends enable damaged cover sections and bows to easily be removed and replaced without disassembling or removing the cover system from its location. A drive assembly can be used to extend and retract the segmented cover system of the present invention.

18 Claims, 3 Drawing Sheets

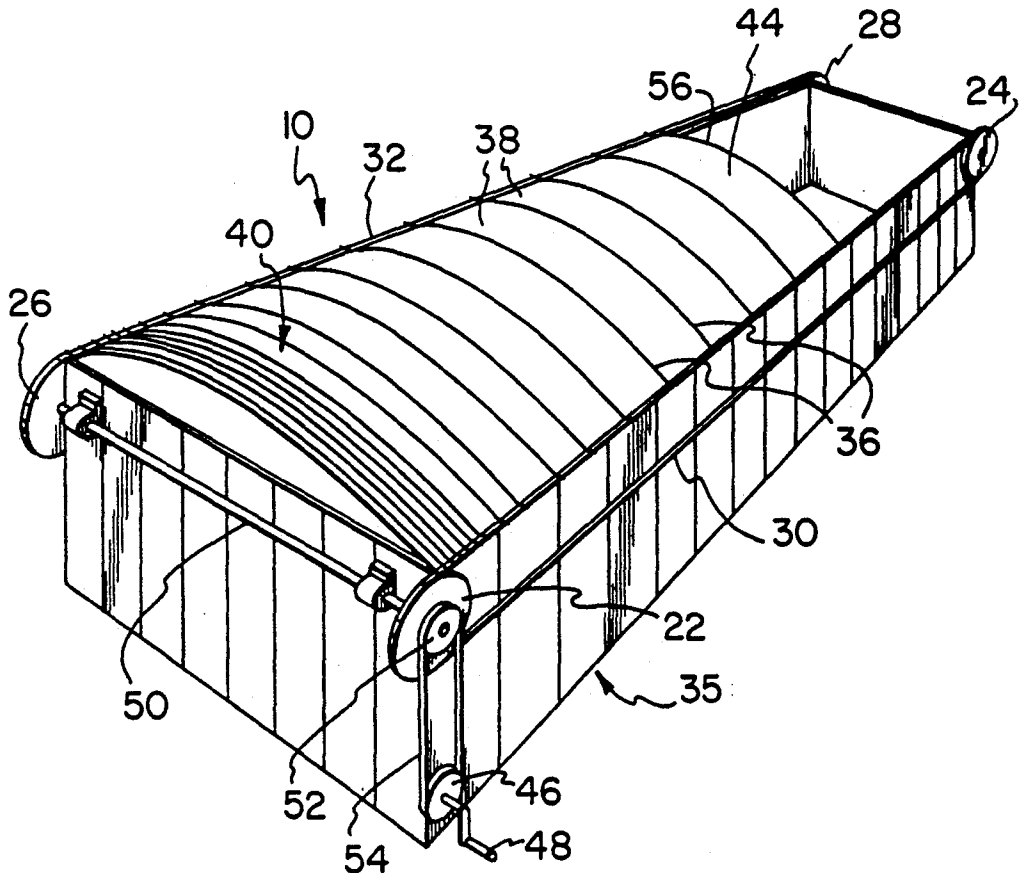

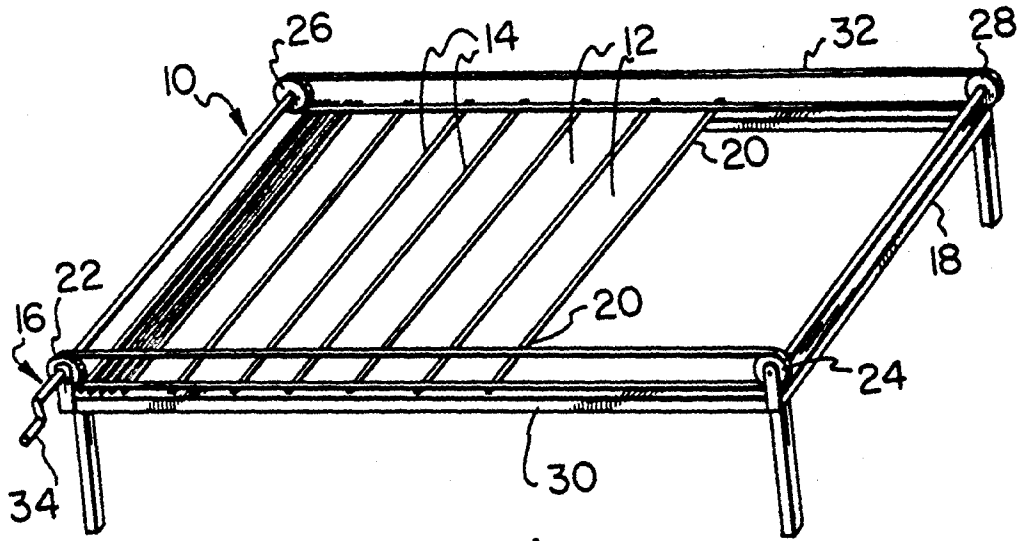

FIG. 1

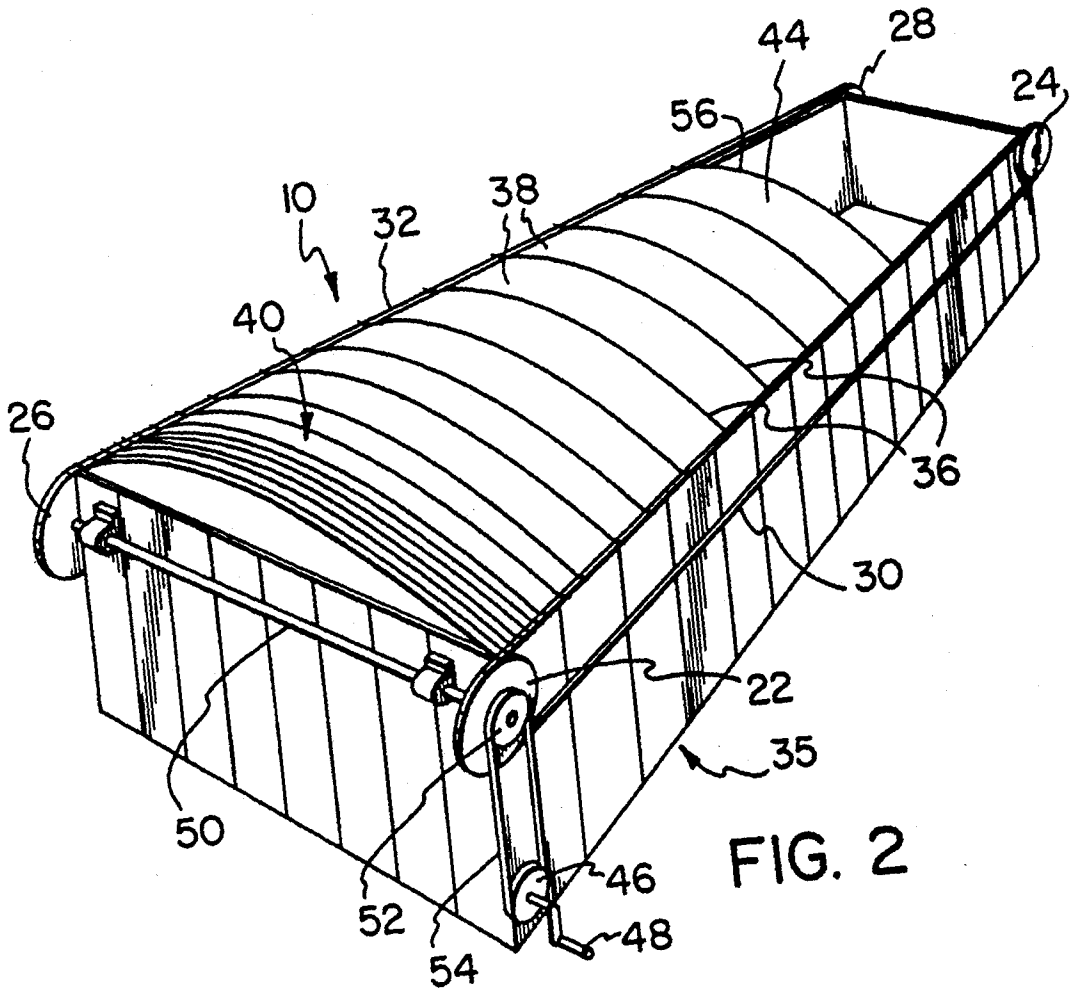

FIG. 2

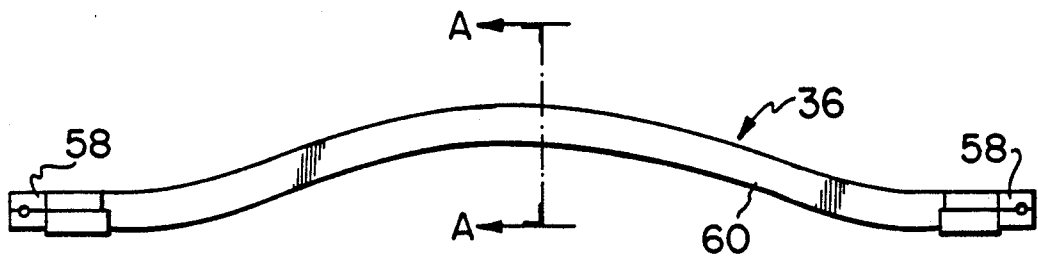

FIG. 3

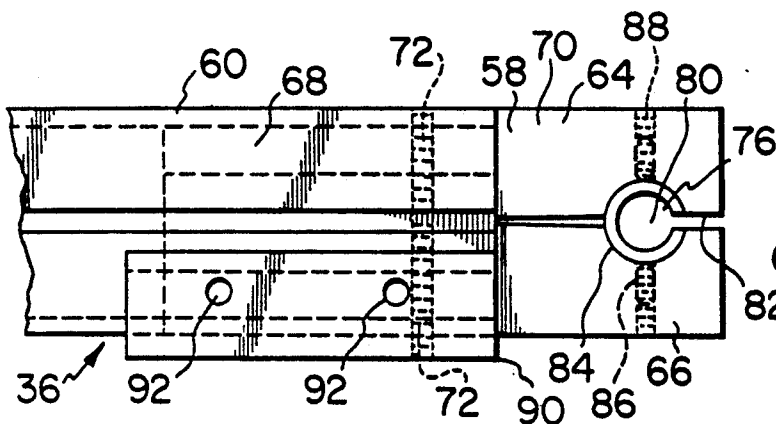

FIG. 4

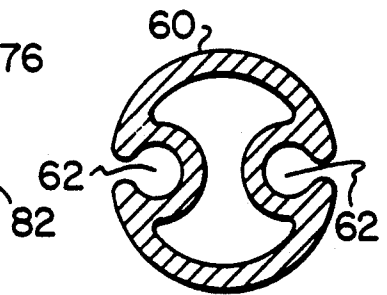

FIG. 5

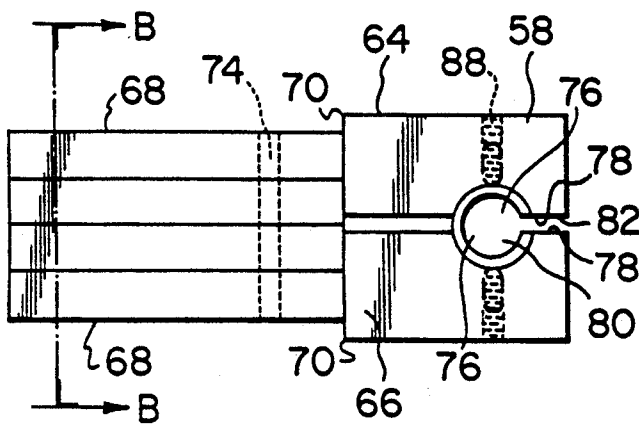

FIG. 6

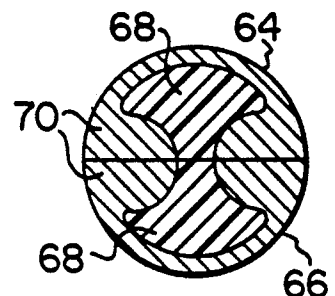

FIG. 7

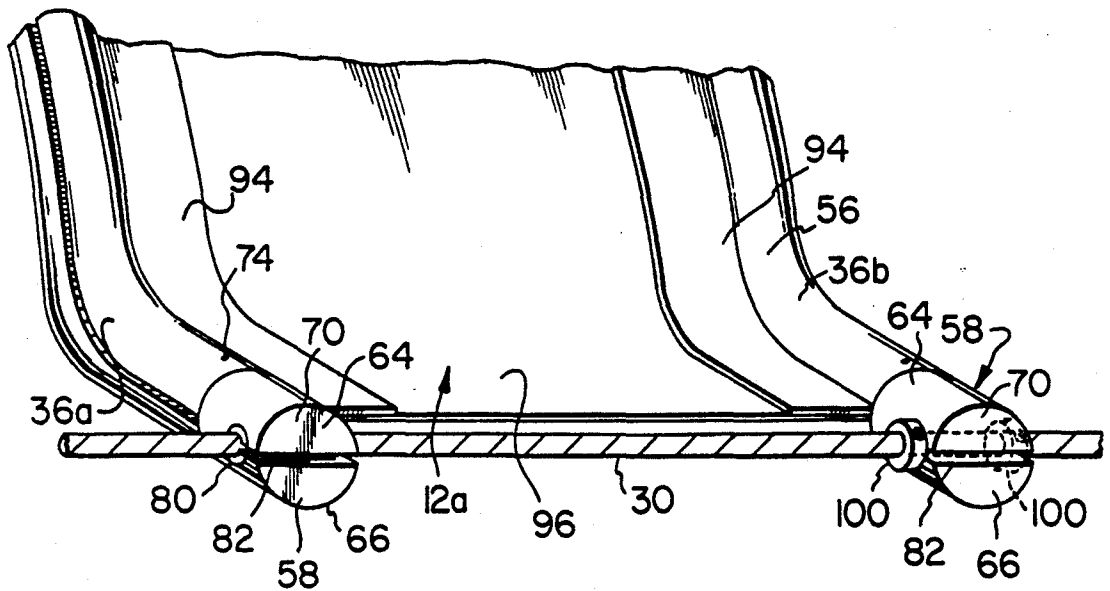

FIG. 8

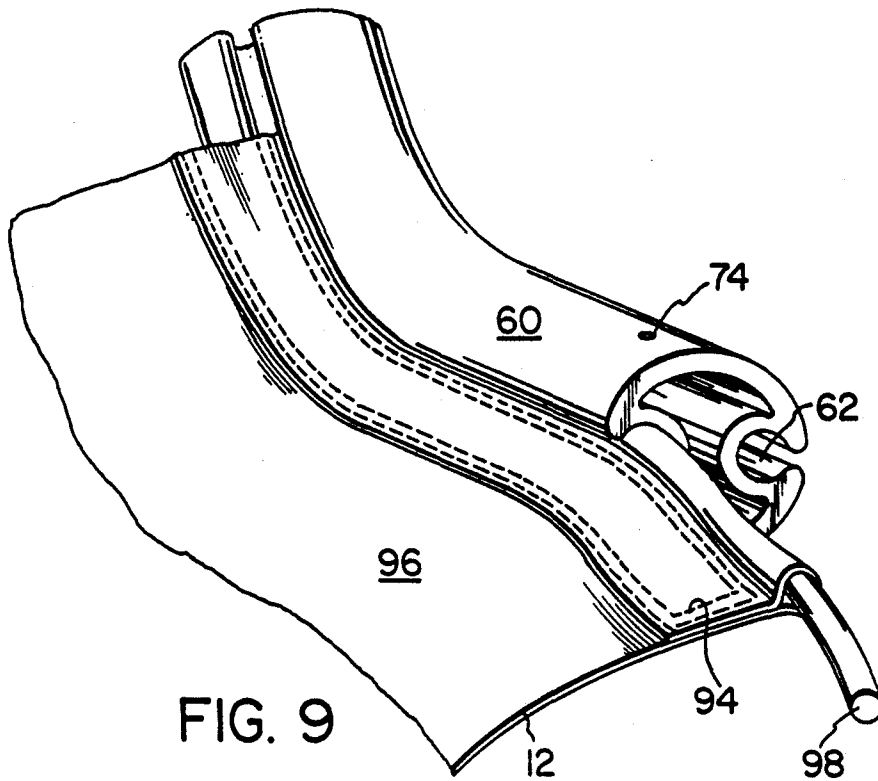

FIG. 9

SEGMENTED COVER SYSTEM

FIELD OF THE INVENTION

The present invention relates to a segmented cover system for covering a large area and more particularly to a retractable segmented covering system for covering the top of truck and trailer bodies.

BACKGROUND OF THE INVENTION

The need for a reliable covering system and particularly a retractable covering system for truck and trailer bodies has long been recognized where the cargo being carried is perishable, a hazardous material, or which could be dangerous to passing motorists such as stones, gravel, asphalt, shale, or any other material which can become a projectile. Moreover, many states are passing laws which mandate the use of covering systems on trucks and trailers. Retractable covering systems have the advantage that they can be operated easily and safely from the ground by one person. They also can be extended and retracted in very little time thereby improving overall efficiency and reducing driver fatigue.

U.S. Pat. Nos. 4,801,171, 4,725,090 and 4,189,178 describe several different truck tarpaulin covering systems which allow a tarpaulin cover to be mechanically extended or retracted from the top portion of a truck trailer. While these retractable cover systems can accomplish their intended purpose once they are installed, they typically require a significant amount of time and effort to install, especially since they are not easily installed by one person. Thus, they are not interchangeable.

Moreover, these systems have a serious drawback if the tarpaulin or its supports become damaged, either during normal operation or during covering and uncovering of the trailer body. It is very difficult to repair or replace these systems if they become damaged and therefore the entire truck can be out of operation for a long period of time until the cover system is completely repaired or replaced. This is because, to replace the cover or the supporting rods, the cables which enable the cover system to be retractable have to be disconnected from all of the supporting bows and these in turn must be disconnected individually from the entire tarp. If a spare tarp is not immediately available, the entire tarp must be sent out for repair even if the damaged area comprises only a small portion of the tarp. Additional delays can occur in repairing the tarp, itself. Even after the tarp is repaired, the whole cover system must be reassembled and reinstalled on the truck trailer, again requiring a significant amount of time and manual labor.

The entire removal and installation process is quite involved and very labor intensive because these tarps can be quite big (typically 10-48 ft. long) and on average are about 34 ft. long and 8-10 ft. wide. In most of these systems, a sleeve is required to be made in the tarp (typically about every 3 ft.) into which each one of the supporting rods must be inserted. This construction results in a very expensive tarp due to the amount of detailed work involved in creating all these pockets. Moreover, it is very tedious and time consuming to insert all of the supporting bows into the tarp pockets as in U.S. Pat. No. 4,189,178 or to connect the tarp to each of the supporting rods as in U.S. Pat. Nos. 4,801,171 and 4,725,090. It is also difficult, due to its weight and bulk, to put the combined tarp and supporting rod assembly onto the truck trailer. Thereafter, the cables by which

the cover is extended or retracted must be individually connected to each supporting rod by feeding it through an opening in the end thereof. As a result of this expensive and involved process, many trucks operate with damaged tarps and supporting rods because it is easier and cheaper to use damaged equipment than to incur the time and expense necessary to fix it. However, using damaged tarps permits material to be blown from the truck trailers and allows water damage to the cargo, thereby defeating the purpose of the truck cover system and possibly being a violation of law.

Due to the frequency with which these tarpaulin covering systems become damaged it would be desirable to have a retractable cover system wherein only the damaged portion could easily be removed and replaced without replacing or disassembling the entire cover system. Similarly, such a cover system would be desirable in certain application, even if it were not retractable.

SUMMARY OF THE INVENTION

Generally, the present invention provides a cover system comprising a plurality of cover sections with a plurality of parallel supporting bows spaced therebetween to form a cover assembly wherein the cover section is detachably connected between successive supporting bows such that the cover section can be removed from the cover system independent of the other cover sections. The cover system of the present invention can be used in almost any industrial, commercial, residential or recreational setting wherein it is desired to have a cover for a large area. It also could be used for small areas, but it is particularly useful for large areas. With the addition of a drive assembly and a frame, the cover assembly can be made retractable thereby expanding its possible uses to almost any structure or container. For example, the present cover system could be used as an awning over a porch or patio, or as a cover for a swimming pool. Preferably, however, the present invention is used as a cover system for large vehicles such as railroad cars and truck and trailer bodies.

One embodiment of the present invention provides a retractable segmented cover system comprising a drive assembly, a plurality of uniquely designed parallel supporting rods or bows and a plurality of cover sections or tarp segments, each one connected between two successive supporting bows to form a cover assembly. Depending on the size of the area to be covered, the present invention uses a varying number of cover sections, which can be of different shapes and sizes, and a varying number of supporting bows. The cover sections extend at least to the edge of the frame and preferably beyond to fully cover the area. One advantage of the present invention is that each bow can be of the same standard design and shape and preferably, each cover section can be of the same standard size and shape. This greatly reduces manufacturing and inventory costs.

The cover sections can be made of any material typically used in cover systems such as canvas, nylon or plastic. It can be rigid or flexible, waterproof or porous, continuous or mesh, depending on the particular application for which it is used. Each supporting bow is comprised of a curved or straight bow center section and two mating bow end sections (bow ends). The cover sections are easily interchangeable since they are detachably connected between each successive sup-

porting bow center section. The bow end sections keep the cover sections in place and also form a guidepath for the drive assembly. The bow ends can be made as a single unit, in which case they are permanently attached to the drive assembly or, preferably, they can be made as two pieces which enables them to be easily connected to or disconnected from the drive assembly.

By the removal of a fastening means which fixedly connects the bow end to the bow center section, each bow end can be removed from mating engagement with its corresponding bow center section and also from connection with the cable of the drive assembly. When two successive bow ends are removed, the cover section therebetween can easily be detached from the adjacent bow center sections by sliding it out. Then, another cover section can be installed. Once the cover section has been replaced, the bow ends can easily be reconnected to the drive assembly and their corresponding bow center sections due to their mating configurations. Then, the fastening means can be reinstalled to firmly connect each bow end to the corresponding bow center section, thereby holding the replacement cover section in place. In a similar manner, a damaged bow can easily be replaced by removing both of its bow ends and sliding it out from between the adjacent cover sections.

A drive assembly can be used to extend and retract the segmented cover assembly consisting of the alternating cover sections and supporting bows. Any number of known mechanical or electrical drive systems can be used. Preferably, the drive assembly comprises an endless cable and two pulleys on each side of the cover assembly with a pulley on each side connected together by a rod. The last supporting bow (i.e. the one closest to the back of the frame or truck trailer) is fixedly attached at each end thereof to the cable on each side of the cover assembly so that as the cable moves it pulls the rest of the bows due to the interconnection of the cover sections and the bows. Preferably, each cable passes through a hole in each of the bow ends of the remaining bows on one side of the cover assembly. Due to the construction of the bow ends, it is very easy to attach or disconnect them from the cable and they do not require the cable to be threaded therethrough which would be impossible with an endless cable. The drive assembly can be either manually operated or motor driven.

Other details, objects and advantages of the present invention will become more readily apparent from the following description of the presently preferred embodiment thereof.

BRIEF DESCRIPTION OF THE DRAWINGS

In the accompanying drawings, a preferred embodiment of the present invention is illustrated, by way of example only wherein:

FIG. 1 is a perspective view of a retractable segmented cover system and frame;

FIG. 2 is a perspective view of a retractable segmented cover system placed on a truck trailer;

FIG. 3 is a side view of one of the curved supporting bows used in a segmented cover system;

FIG. 4 is an exploded view of the end section of the supporting bow shown in FIG. 3;

FIG. 5 is an end view of the center section of the supporting bow shown in FIG. 3 taken along line A—A;

FIG. 6 is a close-up of the bow end of the supporting bow shown in FIG. 4;

FIG. 7 is an end view of the bow end shown in FIG. 6 taken along line B—B;

FIG. 8 is a close up showing the interconnection of a cover section, the neighboring supporting bows and the cable of the drive assembly;

FIG. 9 shows a cover section being removed from the adjacent bow center section.

DESCRIPTION OF THE PREFERRED EMBODIMENT

FIG. 1 shows a retractable segmented cover system 10 of the present invention utilizing a plurality of cover sections 12 interspersed between supporting rods 14 and a drive assembly 16 connected to at least one supporting rod 14 for extending and retracting the cover sections 12. In this particular embodiment, a rectangular frame 18 is used to support the ends 20 of the supporting rods 14 and the drive assembly 16, although any size or shape of frame could be used depending upon the size and shape of the area to be covered. The cover sections 12 extend at least as far as the frame 18 and preferably beyond. The supporting rods 14 are straight, although as shown in the other Figures, they may be curved or formed in any other desired shape. The segmented cover system 10 and frame 18 can be placed over any area where it is desired to have a retractable cover system. For example, the frame 18 may be placed over or be part of a porch or a swimming pool with the retractable segmented cover system 10 operating on the frame 18. The drive assembly 16 is fairly straight forward and is similar to those described in the patents mentioned above. In one embodiment, the drive assembly 16 consists of two pairs of pulleys 22,24 and 26,28 with an endless cable 30 and 32, respectively connected between each pair of pulleys. Pulleys 22 and 26 are drivingly connected by a rod. One of the pulleys 22 has a handle 34 connected to it by means of which it can be turned to extend or retract the segmented cover system 10.

As shown in FIG. 2, the segmented cover system 10 of the present invention is particularly useful for the top of truck trailer bodies 35 or even railroad cars. The embodiment shown in FIG. 2 utilizes a series of curved bows 36 to support and connect the series of tarp segments 38 thereby preventing water from collecting on the cover assembly 40 and also enabling the cover assembly 40 to clear heaped loads. Preferably, the cover system 10 is comprised of a series of tarp segments 38 of a standard, uniform size each connected to and placed between two curved bows 36. The number of curved bows 36 and the number of tarp segments 38 used in the cover system 10 can easily be adjusted depending upon the length of the truck trailer to be covered. If the length of the vehicle does not correspond to a multiple of the standard size of the tarp segments 38, an adjustment can easily be made at either end of the cover assembly 40 by taking up the slack in either the first 42 or last 44 tarp segment.

The drive assembly shown in FIG. 2 comprises two pairs of pulleys 22,24 and 26,28 on each side of the truck trailer body 35 at the top and a third pulley 46 near the base of the trailer body 35 so that the cranking handle 48 can be located in a convenient position for the operator. Again, as in FIG. 1, each pair of pulleys one at the front end and one at the back end on a side of the truck are connected together by endless cables 30,32, respectively. The pulleys at the front end of the truck trailer are connected together by a rod 50 which enables the

pulleys at the front to rotate at the same speed and enables one cranking handle 48 to extend and retract the entire cover system 10. A fourth pulley 52 is mounted on pulley 22 of the first pair and is connected by a third cable 54 to the third pulley 46 to which the cranking handle 48 is connected. By turning the cranking handle 48, the cable 54 connecting the third 46 and fourth 52 pulleys moves, causing the fourth pulley 52 to rotate and since it is fixedly mounted to pulley 22 of the first pair of pulleys, it causes pulley 22 to turn which in turn causes the cable 30 along the top side of the truck trailer body 35 to move. Since the last bow 56 is fixedly connected at each end to each cable 30 and 32, movement of the cables in one direction extends the cover assembly 40 and movement of the cables in the opposite direction retracts the cover assembly 40.

FIG. 3 shows a preferred embodiment of a curved supporting bow 36. Preferably, it is comprised of two bow ends 58 and a bow center section 60. The bow center section 60 is preferably made from a piece of extruded aluminum thereby forming a corrosion-proof foundation for the tarp segments 38 of the cover assembly 40. Various other materials can be used to form the bow center section 60 including steel and plastic. The preferred cross-sectional configuration of the bow center section 60 is shown in FIG. 5, where the round shape provides for increased strength. The generally circular cavities or grooves 62 in the bow center section 60 are parallel and extend along its length on opposite sides and receive and hold an edge of each tarp segment 38 while allowing the cover segment 38 to extend out of the slit but not permitting it to be detached from the bow center section 60. The bow center section 60 of the curved bow 36 can be formed into numerous different shapes and configurations depending upon the particular application.

FIG. 4 shows a close-up of the mated connection between the bow end 58 and the bow center section 60 of the curved bow 36 while FIG. 6 shows the bow end 58 of FIG. 4 when removed from engagement with the bow center section 60. Preferably, the bow end 58 as shown in FIG. 6 is comprised of a separate top part 64 and bottom part 66 although it may be made as a single piece. Having the bow end 58 made from two separate parts is preferable since the top and bottom parts 64 and 66 are identical to each other and can be made very economically using the same mold. The bow ends 58 are preferably made from a high strength durable material such as polyurethane, although plastics, elastomers or other suitable materials can be used.

As shown in FIG. 6, both the top 64 part and the bottom part 66 of the bow end 58 have an extended first portion 68 which can slide into and mate with the end of the bow center section 60, and a semicircular second portion 70 which is adjacent to the end of the bow center section 60 when the bow end 58 is inserted into the bow center section 60. When both top and bottom parts 64 and 66 of the bow end 58 are inserted into the end of the bow center section 60, a fastening means such as pin 72 can be inserted through a hole 74 to thereby fixedly connect the bow end 58 to the bow center section 60. A semicircular groove 76 can be cut in the flat surface 78 of the second portion 70 of the top and bottom parts 64 and 66 to form a generally circular opening 80 when the top and bottom parts 64 and 66 of the bow end 58 are inserted into the end of bow center section 60. The grooves 78 are aligned to form an opening 80 through which the cable 30 or 32 of the drive assembly

16 can pass unobstructed. A channel 82 connects this circular opening 80 to an exterior surface of the bow end 58 to permit the removal of debris from opening 80 which may become lodged therein due to the cable 30 or 32 passing therethrough. Preferably, a durable cable guide 84 is mounted in the groove 76 to prevent wear of the polyurethane material of the bow end 58. This cable guide 84 can be held in place by another screw or pin 86 inserted in a hole 88. Alternatively, a pin could be inserted tangent to the groove 62 between the opening 80 and the end of the bow end 58 to prevent the cable 30 or 32 from wearing its way out of the opening 80.

The bow end 58 can be easily inserted into the bow center section 60, as shown in FIG. 4. The end of the bow center section 60 has a curved wear guard 90 attached to its underside and held in place by several screws 92. This wear guard prevents destruction of the ends of the bow center section 60 from the sliding friction with the frame as the end of the bow center section 60 slides along the frame when it is extended or retracted. Preferably, the wear guard 90 is made of a material such as nylon or teflon to reduce and minimize friction and forms an arc of approximately 120° to match the curve of the bow center section 60. In one embodiment, the wear guard 90 can be formed integrally with bow bottom part 66 thereby forming a groove into which the end of bow center section 60 is inserted. A wear guard 90 can also be used on the top of the end of bow center section 60, especially if the frame forms a top and bottom guide with the bow end 58 passing therebetween.

FIG. 8 shows a close-up of one cover section 12a between two adjacent curved bows 36a and 36b. As can be seen in FIG. 9, the cover section 12 preferably has two edges 94 along its sides which are thicker than the center 96 of the cover section 12a in FIG. 8. This can be easily achieved by folding a portion of the edge over a round flexible material 98 and hemming it with the material 98 remaining inside. This prevents the cover section 12a from pulling out of the groove 62 of the bow center section 60 once it has been inserted in the groove 62 shown in FIG. 9. The cable 30 is not fixed to the bow end 58 but slides freely through the opening 80 therein except for the last bow 56 which is fixedly attached to the cable 30. Alternatively, a flange 100 can be attached to the cable 30 on each side of the last bow 56 such that it impacts the bow end of the last bow 56 and pushes it since it is too large to fit through the opening 80. The remaining bow ends 58 do not need this flange 100 as the cover sections 12 will pull them along and either extend or retract them depending on the direction of movement the cables 30 and 32.

If one or two sections of the cover system 10 are damaged, one only needs to remove the fastening pin 72 in the bow ends 58 at one end of the curved bows 36a and 36b on either side of the damaged cover section 12. These bow ends 58 are then removed from the center sections 60 of the bows 36a and 36b. The cover section 12a can then easily be slid out of the groove 62 in the aluminum extrusion which forms the bow center section 60 and a replacement cover section 12 can be slid into place. The bow ends 58 are then reconnected to the corresponding bow center sections 60 and the fastening pins 72 are reinserted. With this simple procedure, the damaged cover section 12a can easily be removed and the cover assembly 40 has been repaired without its entire removal. This same procedure can be used if one desires to replace certain cover sections of one type (i.e.

waterproof) with cover sections of another type (i.e. mesh) to form a mixed cover assembly.

If instead, a bow 36 is damaged, the same procedure can be used to remove the damaged bow. In this case, however, both the bow ends 58 from the damaged bow 36 would be removed so that the damaged bow 36 could be slid out from between the adjacent cover sections 12. A new bow center section 60 could then be slid into place and the undamaged bow ends 58 can be connected to the new bow center section 60 to form the complete bow 14.

While a presently preferred embodiment of practicing the invention has been shown and described with particularity in connection with the accompanying drawings, the invention may otherwise be embodied within the scope of the following claims.

What is claimed is:

1. A retractable segmented cover system used with a truck trailer comprising a plurality of flexible cover sections with a plurality of substantially parallel supporting bows spaced therebetween and a drive assembly, wherein each cover section is detachably connected between substantially parallel supporting bows, the bows are slideably supported on the truck trailer and at least one bow is fixedly connected to the drive assembly such that the cover system can be extended or retracted by the drive assembly and wherein a cover section can be removed from the cover system independent of the other cover sections.

2. The segmented cover system as described in claim 1 wherein the supporting bows are curved.

3. The segmented cover system as described in claim 1 wherein the drive assembly comprises at least one endless cable and two pairs of pulleys, one pair located on each of two opposite sides of the cover system such that one pulley is mounted adjacent each corner of the frame and the pulleys at a front end of the frame being connected together by a rod; each endless cable being fixedly connected to at least one supporting bow and slideably passing through the other supporting bows.

4. The segmented cover system as described in claim 1 wherein at least one of the supporting bows comprises a bow center section, having a groove along each side substantially parallel to one another, and two bow ends each being detachably connected to an end of the bow center section by a fastening means.

5. The segmented cover system as described in claim 4 wherein the bow ends are detachable from the corresponding bow center sections of substantially parallel supporting bows thereby enabling the cover section therebetween to be detached from the bow center sections.

6. The segmented cover system as described in claim 5 wherein the bow ends are comprised of a top part and a bottom part which are matingly connected to the bow center section.

7. The segmented cover system as described in claim 6 wherein the top and bottom parts have a groove therein, running perpendicular to the grooves in the bow center section, such that when the top and bottom parts are connected to the bow center section the grooves therein are aligned and form an opening in the bow end through which a cable of the drive assembly can pass.

8. The segmented cover system as described in claim 7 wherein at least two edges of the cover sections are thicker than the center thereof.

9. The segmented cover system as described in claim 8 wherein the thicker edges can be inserted into the grooves of the supporting bows.

10. The segmented cover system as described in claim 4 wherein the grooves in the bow center section are generally circular.

11. The segmented cover system as described in claim 7 wherein an open channel connects the opening in the bow end with an exterior surface of the bow end.

12. The segmented cover system as described in claim 11 further comprising a cable guide fixedly set in the grooves of the bow end to prevent wear from the cable.

13. The segmented cover system as described in claim 1 further comprising a wear guard attached to the bow near the bow end to reduce friction between the bow and the frame.

14. A supporting bow for use in a segmented cover system comprising a bow center section having a groove along opposite sides, parallel to one another, which is capable of receiving an edge of a cover section, and a pair of bow ends each detachably connected to one end of the bow center section by a fastening means such that the bow ends hold the cover section in position.

15. A supporting bow as described in claim 14 wherein the grooves are generally circular in shape.

16. A supporting bow as described in claim 14 wherein the bow ends are comprised of a top part and a bottom part which matingly engage the bow center section.

17. A supporting bow as described in claim 16 wherein the top and bottom parts have a groove therein, running perpendicular to the grooves in the bow center section, such that when the top and bottom parts are connected to the bow center section, the grooves therein are aligned and form a generally circular opening in the bow end.

18. A segmented cover system for use on a truck trailer comprising a plurality of cover sections with a plurality of substantially parallel supporting bows spaced therebetween wherein each cover section is detachably connected between substantially parallel supporting bows such that one cover section can be removed from the cover system independent of the other cover sections.

* * * * *

[54] TARPAULIN COVER SYSTEM

[76] Inventor: Nello Cramaro, 779 York Rd., Hamilton, Ontario, Canada

[21] Appl. No.: 1,036

[22] Filed: Jan. 4, 1979

Related U.S. Application Data

[63] Continuation of Ser. No. 729,237, Oct. 4, 1976, abandoned.

[30] Foreign Application Priority Data

Jan. 29, 1976 [CA] Canada 244497

[51] Int. Cl.² B60J 7/00

[52] U.S. Cl. 296/105; 296/100

[58] Field of Search 296/98, 100, 101, 104, 296/105, 109, 137 R, 137 B; 105/377; 4/172.12, 172.14; 160/84 R

[56] References Cited

U.S. PATENT DOCUMENTS

2,757,042	7/1956	Schultz	296/100
3,500,895	3/1970	Silvernail	296/105
3,560,045	2/1971	Finneman	296/137 B

FOREIGN PATENT DOCUMENTS

939418	1/1974	Canada	296/105
--------	--------	--------------	---------

Primary Examiner—Joseph F. Peters, Jr.
Assistant Examiner—Randall A. Schrecengost
Attorney, Agent, or Firm—Ladas, Parry, Von Gehr, Goldsmith & Deschamps

[57] ABSTRACT

A tarpaulin cover system for use in trucks eliminates the need for usual side tracks for guiding the tarpaulin supporting rods. The rods are instead guided by flexible means such as cables which are simultaneously used for driving the front edge of the tarpaulin when unfolding or folding same. The invention substantially enhances the operative reliability of the device, reduces costs thereof and simplifies its installation.

4 Claims, 7 Drawing Figures

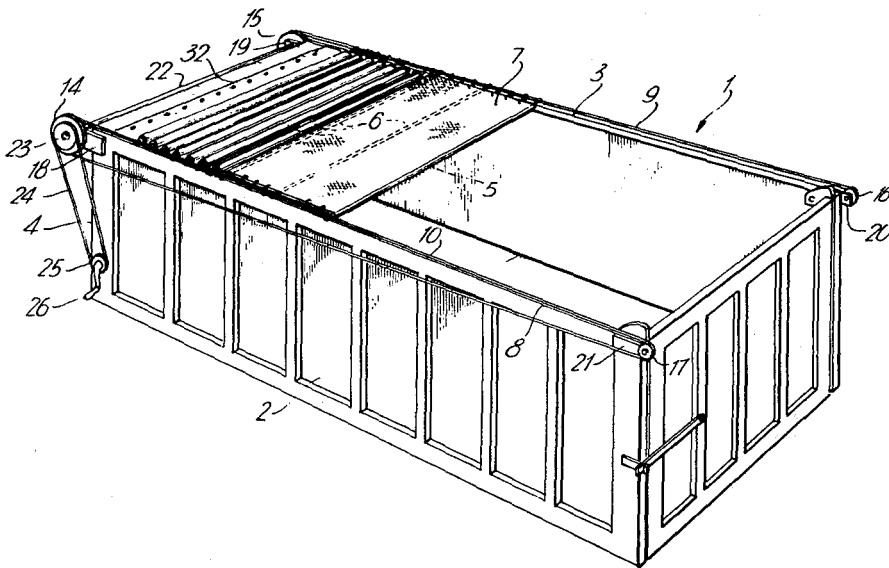

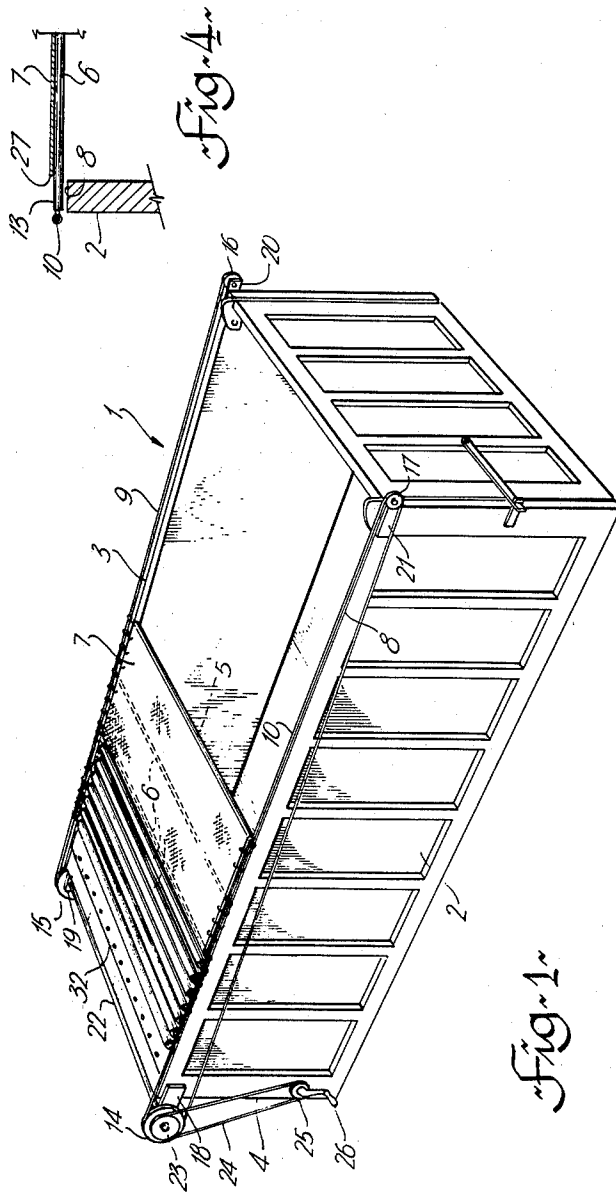

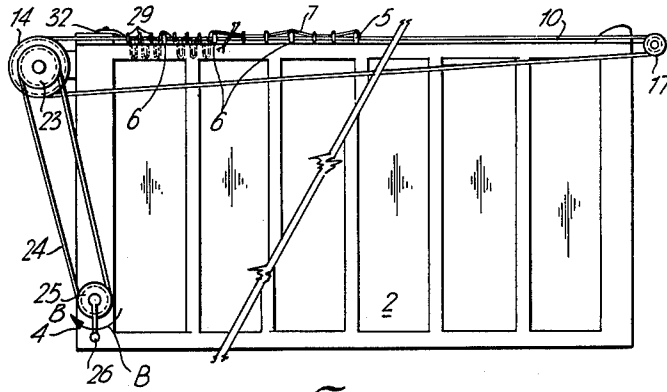

Fig. 3

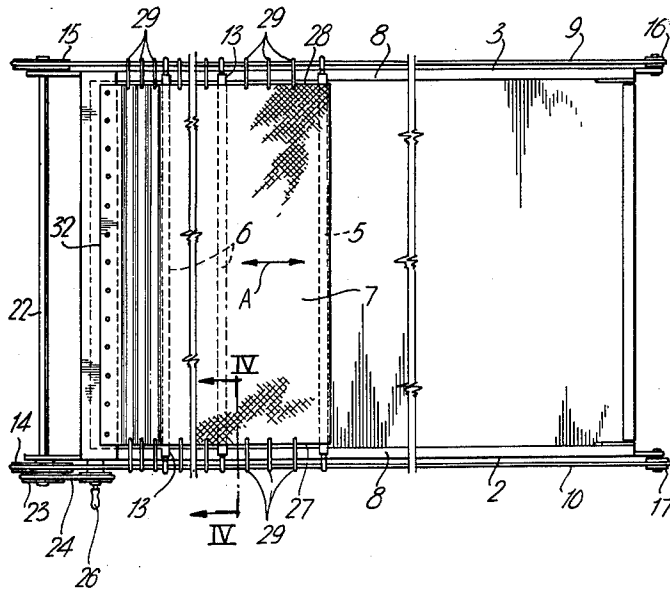

Fig. 2

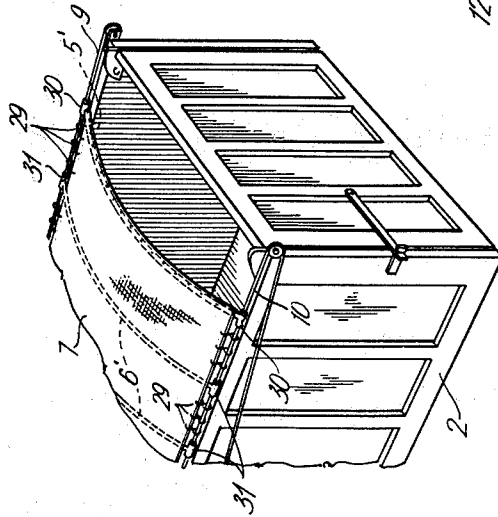
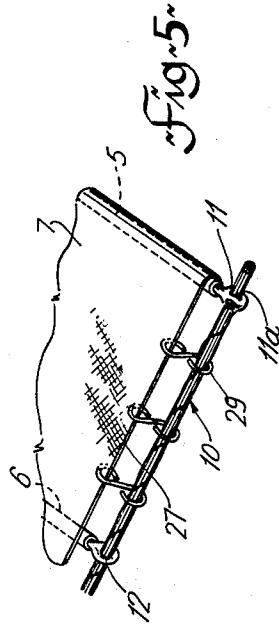
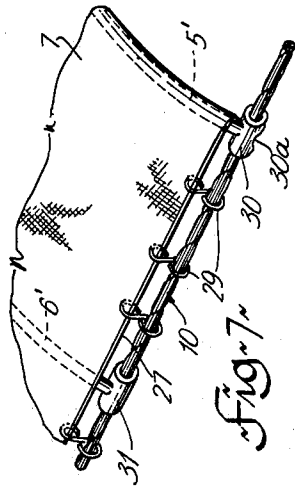

Fig. 6

TARPAULIN COVER SYSTEM

This is a continuation of application Ser. No. 729,237 filed Oct. 4, 1976 and now abandoned.

This invention relates to a new tarpaulin cover system for use in a truck box. More particularly, the present invention relates to a tarpauline cover system suitable for vehicles such as dump trucks or the like, frequently used in hauling sand, gravel, rocks etc.

The suitability of truck covers has long been recognized as suitable means for reducing environmental pollution and danger to motorists following a dump truck or the like. It has also been recognized by many that overall structure of a tarpaulin system must meet several basic requirements in order to be really effective. Above all, a tarpaulin system should be relatively easy to install on an existing truck box without the need for considerable modifications of the parts thereof. Furthermore, the cover system must be simple and thus inexpensive to produce. Another requirement is a high reliability of the cover system. In other words, even when using the cover system in connection with coarse, bulky material such as rocks or the like, the cover system must not be subject to frequent damaging either by the hauled material or by the loading machinery, particularly in case of side loading. Another essential requirement, particularly for application in dump trucks, is the possibility of remote folding and unfolding of the cover.

Although the above requirements have long been established, the presently used and known devices of this type do not meet all of them.

Usually the meeting of one of the requirements results in failure to comply with another. The known cover systems use, for instance, tracks for mounting on the side walls of a dump truck box. Such tracks are frequently either subject to damage or too heavy and thus cumbersome to install, or both. A typical example of prior art in this field can be found in Canadian Pat. No. 895,191 issued Mar. 14, 1972 to W. Michel, U.S. Pat. No. 3,472,548 issued Oct. 14, 1969 to S. Comisac, U.S. Pat. No. 2,559,310 issued July 3, 1951 to McNavage and many other prior art references.

It is an object of the present invention to overcome the drawbacks of the known cover systems and to meet, to an optimum degree, all of the requirements as referred to above, in a manner superior to the known devices of this type.

In broad terms, the present invention solves the above problem by entirely avoiding conventional tracks in the actual sense of the word as referred to in prior art. In other words, the present invention utilizes the means for moving the tarpaulin along the truck box for simultaneously guiding of its components so as to maintain same in proper position with respect to the truck box.

According to the present invention, a tarpaulin cover system is provided for use in a truck box including two generally upright side walls and a front wall, such as a dump truck or the like. The system of the present invention belongs to the known type having a plurality of tarpaulin supporting rods including a leading rod and a plurality of intermediate rods, all of which extend across the truck box. The group of covers to which the present invention relates also is known as providing means for moving the rods along the top of the truck box to unfold or to fold the tarpaulin. Guide means for maintaining the ends of the rods in proximity to respective upper edges of the side walls belong to a further

typical feature of the art to which the present invention relates. In the present invention, the guide means and the means for moving the rods consist of elongated, flexible means, such as a cable, arranged to be located along the top edge of each of the side walls generally parallel therewith. The leading rod is provided with means for fixedly securing the rod to the flexible means. The intermediate rods, on the other hand, are provided with means for securing the rods to the flexible means for slidable movement therealong. The elongated flexible means is arranged to be operatively connected to drive means for movement of the flexible means along the upper edges of the truck box. The invention thus results in a new and useful tarpaulin cover system which is not only extremely resistant to damage during the loading of bulky material or the like but which, at the same time, is relatively simple and thus inexpensive to produce. Furthermore, the inventive system is much easier to install to an existing dump truck box than the known devices of the above type.

The invention will now be described by way of a preferred embodiment thereof and by way of a slight modification of such embodiment, with reference to the accompanying drawings in which:

FIG. 1 is perspective view of a truck box wherein the rods and thus the cover of the box are arranged in a generally planar relationship with the top of the truck box;

FIG. 2 is a schematic top view of FIG. 1;

FIG. 3 is a schematic side view of FIG. 1;

FIG. 4 (on the sheet of FIG. 1) is a detail IV of FIG. 2;

FIG. 5 is a schematic detail of the embodiment of FIG. 1;

FIG. 6 is a partial perspective view of a modification of the embodiment of FIG. 1; and

FIG. 7 is a schematic sectional detail similar to FIG. 5 but showing the embodiment of FIG. 6.

The tarpaulin cover system shown in the drawings is applied to a truck box 1 which includes two side walls 2, 3 and a front wall 4. A plurality of rods 5, 6 is provided for supporting a flexible tarpaulin 7. The system of rods 5, 6 includes a leading rod 5 and a plurality of intermediate rods 6, as best seen from FIG. 1. The tarpaulin 7 is fixedly secured to the rods 5, 6, e.g. by cementing, stitching or the like. The rods 5, 6 extend across the truck box 1 and are arranged for movement along the top of the truck box 1, in the direction A (FIG. 2), to fold or to unfold the tarpaulin 7.

The system as shown in the drawings further comprises guide means for maintaining the ends of the rods in proximity to respective upper edges of the side walls 2, 3, one such upper edge 8 being shown in FIG. 4. The guide means is a system of flexible cables 9, 10, also being referred to as "elongated flexible means". As best seen from FIG. 4, the cable 10 is located along the top edge 8, generally parallel therewith.

It will be appreciated from FIG. 5 that the leading rod 5 is provided with a passage 11 through which passes the cable 10. The passage 11 is flattened at 11a so as to fixedly secure the ends of rod 5 to a first portion of each of the respective cables 9, 10.

On the other hand, as shown in FIG. 5, the intermediate rods 6 have each an eye 12 through which passes the respective cable 9, 10, so that the intermediate rods 6 are each slidable along the cables 9, 10. The cables 9, 10 are each operatively connected to drive means which will be described in greater detail hereinafter. In general

terms, the drive means are arranged to move the cable along the upper edge 8 of the respective side wall 2, 3; the portions of the cable passing slidably through the eyes 12 can also be referred to as an embodiment of "second portions" of the flexible means.

It will be apparent from FIG. 4 that the overall length of each of the rods 5, 6 is such that the rod 6 can rest with its end portion 13 on the upper edge 8 of the side wall of the truck box 1.

Turning now to the above mentioned drive means, it is firstly to be appreciated that the elongated flexible means of the embodiment shown in the drawings are endless cables 9, 10 each arranged to train about a front pulley 14, 15 and about the respective rear pulley 16, 17. It will be appreciated that the pulleys 14-17 are secured to the upper end portions of the respective side walls 2, 3, of the truck box by brackets 18-21. As best seen from FIG. 2, the pulleys 14, 15 are both fixedly secured to an axle 22 so that they can only rotate in common. Fixedly secured to the left-hand end of the axle 22 is another pulley, also referred to as first pulley 23. The pulley 23 is operatively connected by a drive belt 24 with a second pulley 25 to which is fixedly secured to crank 26 for manually rotating the pulley 25. It will be appreciated that on turning the crank 26 the overall system of the pulleys can be driven. The second pulley 25 is provided with adjustment means (not shown) for adjusting the tension of belt 24.

With reference to FIG. 2, it will be seen that, in this embodiment, the tarpaulin 7 has two side edges 27, 28 which are generally coincident with the inside extremities of the top edges 8 of the respective side walls 2, 3, to span across the substantially entire width of the truck box, and to also allow for folding between the side walls. The tarpaulin 7 is provided at its edges 27, 28 with closed "S"-shaped connectors 29 which are equidistantly spaced between adjacent rods 6-6; 6-5. One eye of each of the connectors 29 is secured to the edge portion of the tarpaulin 7, while the other eye of each of such connectors slidably receives the respective cable 9, 10. The edge portions of the tarpaulin between adjacent supporting rods 5, 6 are thus additionally secured to the cables 9, 10 to reduce the overall height of the pleats of the tarpaulin when same is in a folded position.

Turning now to the embodiment of FIGS. 6 and 7, it will be seen that the rods 5' 6' of this embodiment are of the type of upwardly arched bows. The end portions of the rods 5' 6' are provided with tubular members, of which the tubular members 30 of the rod 5' are flattened at 30a so as to fixedly secure the end portions of the rod 5' to the cables 9, 10. On the other hand, the passages of tubular members 31 of the intermediate rods 6' allow for free passage of the respective cables 9, 10. The purpose of the tubular members is to maintain the upwardly arched rods in a generally upright position. It will be appreciated that the number of cross bars 6 in the embodiment of FIG. 6 may be reduced in comparison with the embodiment of FIG. 1, to provide for a reasonably storage space when the tarpaulin is in folded position as the tubular members may prevent the rods from becoming as closely stacked as in the embodiment of FIG. 1. Due to the provision of the connectors 29 as referred to hereinabove, such reduction in the number of intermediate rods 6 does not pose a serious problem.

The tarpaulin 7 in FIG. 2 is shown in a partly unfolded position. It will be appreciated that the turning of crank 26 in the direction of the arrow B (FIG. 3) will result in the leading rod 5 (FIG. 2) moving to the right

hand side, or towards the back of the truck box 1. The sections of tarpaulin between individual intermediate rods 6 are gradually unfolded until the leading rod 5 reaches the back of the truck box, whereupon the tarpaulin 7 is fully stretched to entirely cover the top of the truck box 1. The front end 32 of tarpaulin 7 is, of course, fixedly secured to the top edge of the front wall 4. When it is desired to fold the tarpaulin, the crank 26 is turned in a direction opposite to the direction B whereupon the leading rod 5 moves to the left of FIG. 2 such movement resulting, first, in creation of folding pleats between the leading rod 5 and the adjacent intermediate rod 6 etc. The overall sequence of the folding and unfolding of the tarpaulin 7 is much the same as in the known prior art and therefore need not be described in greater detail.

It will be appreciated that the present invention thus provides a simple and thus relatively inexpensive device in which the danger of a damage or inoperativeness during the loading, due to snow, ice, etc., is substantially reduced when compared with track systems due to the fact that the track-type guide system of prior art is eliminated and the flexible means of this invention is not subject to permanent deformation, clogging, etc., often encountered with known tracks. The device is simple to install on existing truck boxes as all that is required is the fixing of the brackets 18, 19, 20 and 21 to the box, together with the mounting of the drive pulley 25. In particular, it will be appreciated that the application of the present invention to an existing dump truck does not require any modification of the side walls of the existing truck, as is frequently the case of the known track-guided tarpaulin cover systems of prior art. The device according to the present invention is extremely simple to manufacture and thus substantially reduces the initial cost of the system.

Those skilled in the art will readily appreciate various modifications of the above embodiments. For instance, one might consider the replacement of the endless cables 9, 10 with two cables with reeling and unreeling arrangement at both ends of the truck box. When using the present invention with a drip-waterproof tarpaulin, it would obviously be of advantage to make the tarpaulin somewhat wider so as to cover the edges of the walls of the truck box. To secure the folding of such an embodiment, one might have to apply more power to the drive system. Another obvious modification would reside in automatic operation of the drive by providing an electric motor which might be operatively connected to the axle 22, to further simplify the overall arrangement. However, these and many other modifications of the device would still fall within the scope of the present invention as defined in the accompanying claims.

The embodiments of the present invention in which an exclusive property or privilege is claimed are defined as follows:

1. In combination with a truck box including a front wall and two generally upright side walls each having a generally horizontal top edge, a tarpaulin cover system including a tarpaulin; tarpaulin supporting rods fixedly secured to the tarpaulin and including a leading rod and a plurality of intermediate rods, said rods extending across said truck box; means for moving and guiding said rods along the top of said truck box to unfold or fold and to guide said tarpaulin and to maintain respective ends of the rods in proximity to the respective upper edges of said side wall, wherein:

5

- (a) the length of each of said rods is in excess of the width of said box, while the width of said tarpaulin is less than the width of said box, each rod having two end portions disposed between the respective ends of the rod and a respective side edge portion of said tarpaulin, each of said end portions being fully exposed and resting on the top edge of the respective side wall of the box;
- (b) said means for moving and guiding said rods including two flexible cable means each secured to the box, one of each of the cable means extending along the respective horizontal top edge in proximity to same and exteriorly of the box;
- (c) each of the intermediate rods having at each end thereof a transverse passage means for slidably receiving the respective cable, the spacing between each passage means and the respective adjacent edge of the tarpaulin being greater than the thickness of the respective side wall at the respective top edge thereof;
- (d) each of said cable means being fully exposed along generally the entire length thereof, whereby undesired accumulation of solid particles or the like in

5

10

15

20

25

30

35

40

45

50

55

60

65

6

proximity to the respective cable is prevented, to improve reliability of operation of said system.

2. The combination of claim 1, wherein each of said cable means is an upper run of an endless cable training about a pair of pulleys secured for rotation at the front and the back of the box exteriorly thereof, respectively, said leading rod being fixedly secured to the respective cables; said combination further including means for coupling at least one of the respective pairs of pulleys secured at the front or at the back of the box, for simultaneous movement.

3. The combination of claim 2, further including connector means for slidably connecting a portion of the respective edge of the tarpaulin disposed between two adjacent rods, to the respective portion of the cable means.

4. The combination of claim 2, wherein said rods are each of the type of an upwardly arched box, each of said passage means being a tubular member fixedly secured to the respective ends of the respective rod and extending generally horizontally across the ends thereof, the length of each tubular member being greater than the width of the respective rod.

* * * * *

Dec. 10, 1968

R. L. HALL

3,415,260

EXTENSIBLE CANOPY STRUCTURE

Filed July 17, 1967

3 Sheets-Sheet 1

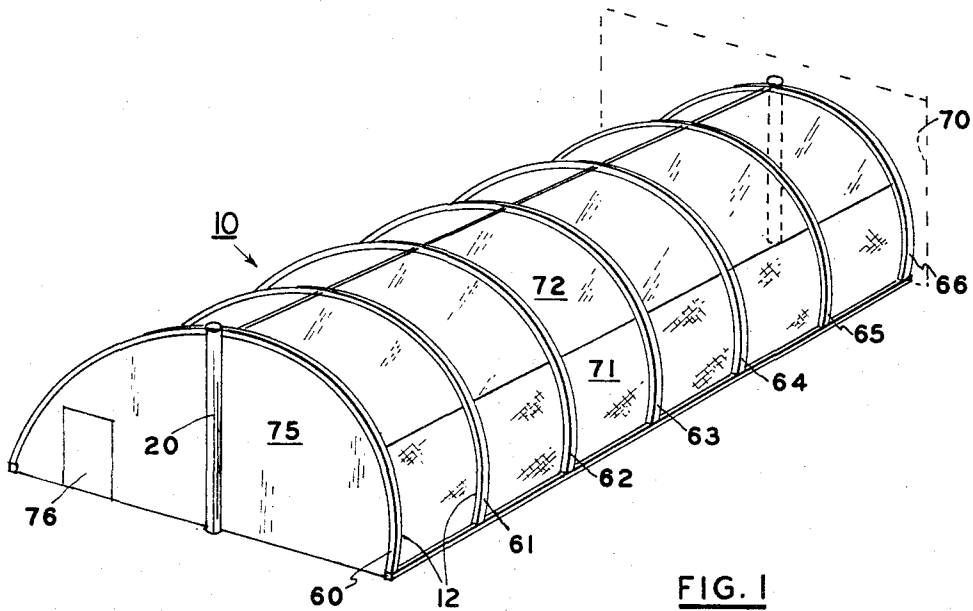

FIG. 1

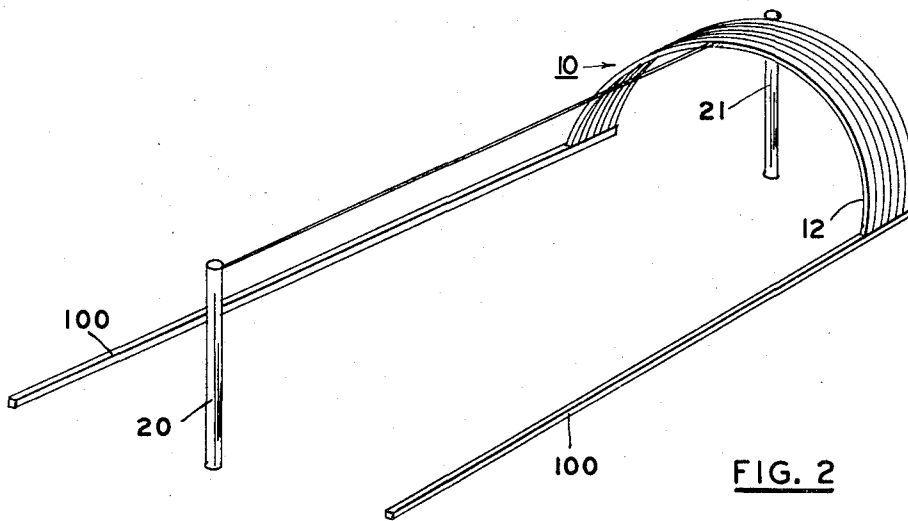

FIG. 2

INVENTOR.

RAYMOND L. HALL
BY

Ralph R. Roberts
AGENT

Dec. 10, 1968

R. L. HALL

3,415,260

EXTENSIBLE CANOPY STRUCTURE

Filed July 17, 1967

3 Sheets-Sheet 2

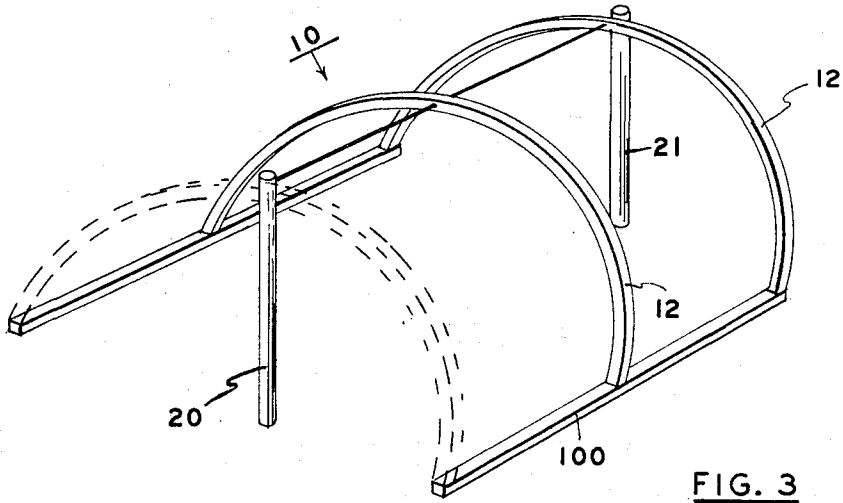

FIG. 3

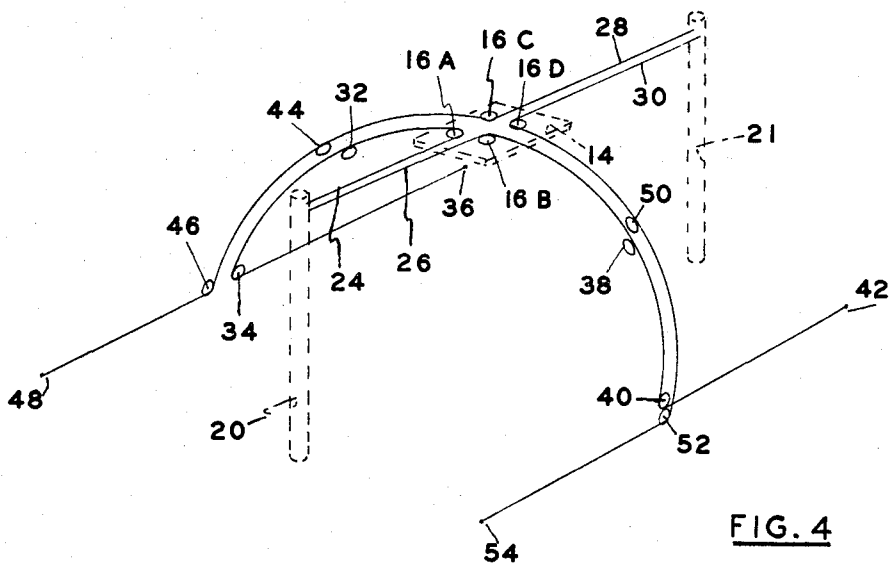

FIG. 4

INVENTOR.

RAYMOND L. HALL

BY

Ralph R. Roberts
AGENT

Dec. 10, 1968

R. L. HALL

3,415,260

EXTENSIBLE CANOPY STRUCTURE

Filed July 17, 1967

3 Sheets-Sheet 3

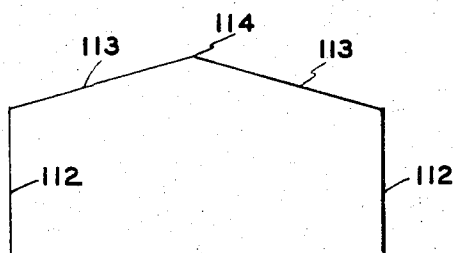
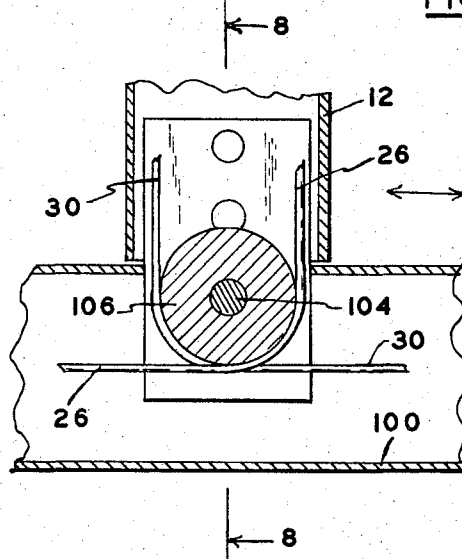
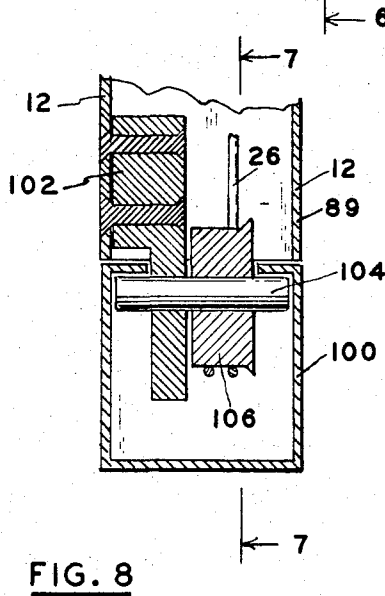
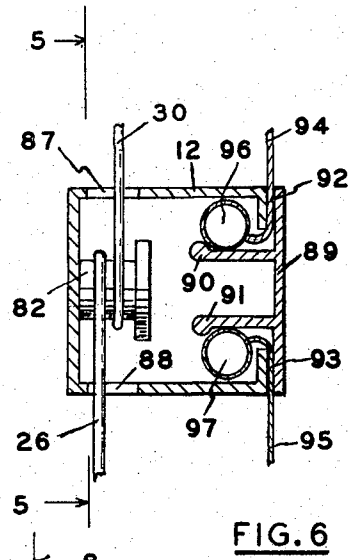
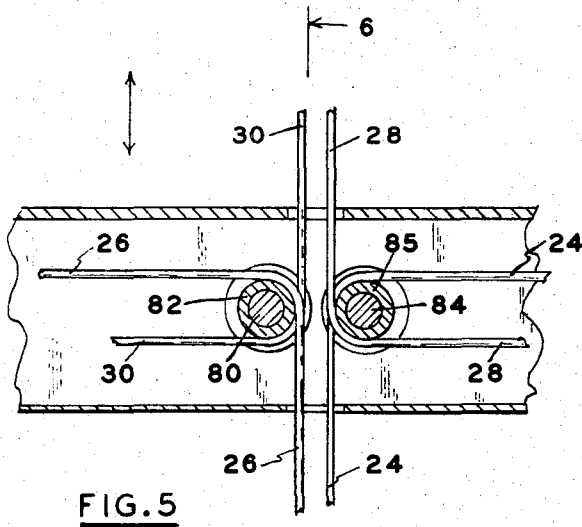

INVENTOR.
RAYMOND L. HALL
BY
Ralph R. Roberts
AGENT

FIG. 9

1

2

3,415,260
EXTENSIBLE CANOPY STRUCTURE
 Raymond L. Hall, 19 Hamilton Court,
 Whippany, N.J. 07981
 Filed July 17, 1967, Ser. No. 653,696
 15 Claims. (Cl. 135-1)

ABSTRACT OF THE DISCLOSURE

A plurality of frames or arch members are independently movable between two fixed posts or support members and each is maintained in aligned parallelism by four cables, each cable being disposed in a Z-pulley arrangement. Between each frame there may be provided a flexible cover or screen or a combination thereof so that when assembled the structure may be expanded to its maximum limit to provide an enclosure or canopy and may be moved to its minimum or closed limit for storage of the structure and cover.

Background of the invention

Field of the invention

The field of art to which this movable structure pertains is the general class of tents, canopies, umbrellas and canes and particularly to the subclass of tents and tent frames and folding frames as well as canopies with expandable frames. Another field of art to which this invention might pertain is the general class of land vehicles, bodies and tops and in particular to the general subclass of tops and more particularly to load covers and collapsible standing tops.

Description of the prior art

Collapsible or retractable covers or extensible canopies are generally represented as in U.S. Patent to Richard, No. 3,041,104 of June 26, 1962 and in the patent to Openshaw, No 3,298,732 of Jan. 17, 1967. A patent of similar nature was issued to Greenberg, No. 3,310,338 on Mar. 21, 1967 while U.S. Patent No. 3,240,217 to Bird of Mar. 15, 1966 also shows an erected structural assembly in which arches or frames are used to support a flexible covering.

Summary of the invention

This invention contemplates the use of a plurality of like sized arches or frames which are generally planer in construction and use. Each of these frames when erected is operatively maintained in a vertical alignment by means of a cable assembly. Each of these frames is maintained in a vertical relationship by separate cable assemblies and is adapted to be moved independently forwardly and back while being maintained in an aligned and vertical manner. It is generally contemplated that this structure may be used as an expandible cover for a swimming pool or provide an expandible covering for a patio and the like and that as such, this structure provides a support means for a flexible roof covering whereas the sides may also have a flexible screen or a flexible wall which would provide for the exclusion of insects or of moisture as well as heat or cold.

The present invention provides an assembly in which each frame is supported by four cables and is retained in a vertical manner by means of pulleys or guides. These cables are attached at their ends and are guided and retained by pulleys and the like which are attached to the frame so that as the frame is moved the cables limit the movement of all portions of the frame so that it may be moved only as guided by the cables. The covering between frames is contemplated to be of plastic film and the

like which is preferably flexible and permits the frames to be brought into a near contiguous relationship to each other. The maximum extension of the structure is determined by the distance between two vertical support means which may be in the nature of posts which carry the upper and outer ends of the cables.

It is contemplated that the frames of the assembly will be made of light weight extrusions and of relatively inexpensive cost. The extent of flexible material between frames also is of low cost and weight so that for the assembly and operation of the extensible structure there is no need of extensive erecting facilities. Operation for the opening or closing of the structure requires little force and may be moved according to the weather as to sunshine, rain, heat or cold. As a pool cover it extends the useful season length of pool use. If desired the sides and roof portions may be rigid panels that telescope onto one another.

It is an object of this invention to provide a structural assembly adapted for extension to a maximum condition and at the other limit movable to a condensed condition, and between these limits the structure may be moved as desired to any open, partially open or closed position and in the position the structure will support the desired covering.

It is a further object of this invention to provide an extensible canopy structure having at least one movable arch member maintained in its erected and substantially vertical manner by means of cables extending from a first fixed support position to a plurality of cable guide means in the arch member and thence to another fixed support position.

It is a still further object of this invention to provide an extensible canopy structure in which a movable arch member is maintained in a substantially vertical relationship to a ground or support surface, the arch member being movably supported by at least four cables and the like, each cable extending from a fixed support and in a line normal to the plane of the frame to a cable pulley or guide near or at the apex of the frame, said cable carried and guided around this pulley and continuing parallel to the frame to yet a second pulley or guide near or at the outer lower end of the frame, said cable thence being carried or guided around this second pulley and then in a line normal to the plane of the frame, the cable is continued to and attached to another fixed support.

Intent of the disclosure

Although the following disclosure offered for public dissemination is detailed to ensure adequacy and aid in understanding of the invention, this is not intended to prejudice that purpose of a patent which is to cover each new inventive concept therein no matter how it may later be disguised by variations in form or additions of further improvements. The claims at the end hereof are intended as the chief aid toward this purpose, as it is these that meet the requirement of pointing out the improvements, combinations and methods in which the inventive concepts are found.

There has been chosen a specific embodiment of the canopy structure and a preferred and alternate means for guiding the cables to and through a movable arch of the structure, the embodiments chosen for the purposes of illustration and description of the structure and method supporting these arches are shown in the accompanying drawings forming a part of the specification wherein:

Brief description of the drawings

FIG. 1 represents an isometric view of the extensible canopy structural assembly of this invention and in an expanded and/or fully open position;

FIG. 2 represents an isometric view of the extensible canopy structure of FIG. 1 but with the movable arches moved to the closed position;

FIG. 3 represents an isometric view of the structural assembly and showing one movable arch frame and the arrangement of cables therefore with said movable frame midway between two fixed support ends;

FIG. 4 represents an isometric and somewhat schematic view of a four cable arrangement for one arch frame;

FIG. 5 represents an enlarged fragmentary sectional plan view of a pulley arrangement for supporting the apex of the arch, the view generally taken on the line 5—5 of FIG. 6;

FIG. 6 represents a sectional view of the pulley arrangement of FIG. 5 with the view taken on the line 6—6 of FIG. 5;

FIG. 7 represents an enlarged fragmentary sectional side view of a pulley arrangement for guiding and supporting the bottom outward end of a movable arch member, the view taken on the line 7—7 of FIG. 8;

FIG. 8 represents a sectional view of the pulley arrangement of FIG. 7 but with the flexible material retaining means omitted, the view taken on the line 8—8 of FIG. 7, and

FIG. 9 represents a somewhat diagrammatic view of an alternate form of arch or frame.

Referring now to the drawings in detail in which like numbers refer to like members throughout the several figures and in particular to the FIGS. 1, 2, 3 and 4, it is to be noted that an arch frame as in this preferred embodiment is generally indicated as 10 in which a curved or arcuate member 12 is retained at its ends and at an apex or peak. At the apex there may be provided a plate 14 upon which there are carried pulleys or cable guides 16 each adapted to receive and redirect a cable to other guides. To support the ends of the cables there are provided front and rear posts 20 and 21 which are about the same height as the peak of the arch frames and carry the upper outer ends of the cables.

As diagrammatically shown particularly in FIG. 4, it is to be noted that cables 24 and 26 are attached to and are supported by the post 20 and in like manner cables 28 and 30 are attached to and are carried by the post 21. This post 21 is not needed if the ends of these cables are attached to a wall or some other structure against which this extensible framework is adapted for storage.

The cable 24 extends from post 20 to and around the leftward pulley 16A thence down or inside member 12. When carried outside the member the cable is movable in and through a guideway 32 and then down to a pulley or cable guide 34 near the bottom portion of the member 12. The cable 24 is guided around this pulley and normal to the plane of the member 12 continues back to a wall mount or attachment 36. Cable 26 extends from post 20 to and around pulley 16B and down or inside the right portion of member 12. If necessary it is carried through a cable guide 38 and thence down to a lower pulley 40 and guided around this pulley continues rearwardly to a wall mount 42.

In like manner cable 28 is attached to the post 21 or to a wall and extends forwardly therefrom to a pulley or cable guide 16C thence down or inside the left upper portion of member 12 to a cable guide 44 and thence down to and around a lower pulley 46 and forwardly to an attaching point 48. Similarly, cable 30 extends forwardly from the post 21 to a pulley 16D and parallel to the frame 12 leads outwardly and downwardly to a cable guide 50 and thence down to a lower pulley 52 and around this pulley forwardly to an attaching point 54.

Although the cable arrangement shown in FIG. 4 is shown as for only one frame many frames may be used with four such cables used for each movable frame so that each frame is independently retained and as it is moved is maintained in the erected position. It is, of course, readily apparent that the pulleys 34 and 46 may

be freely rotatable on a common shaft as also can the pulleys 40 and 52, this arrangement being described below. The attaching of the ends of the cable at points 42, 54, 48 and 36 can be either to the ground or to fixed wall structures. The cables are attached with no slack and so that the desired tension in the cable is maintained and remains the same as the frame is moved back and forth.

Referring now to FIG. 1, it is to be noted that the structure embodies a plurality of frames, as for example, a first or forward frame 60 and a first rightwardly adjacent frame 61. Other adjacent frames 62, 63, 64 and 65 are spaced rearwardly toward a rear frame 66, which frame may be attached to a wall 70 indicated in phantom outline. On these various frames are indicated side portions 71 which may be a flexible screen, either plastic or metal, or may be a thin flexible plastic film either clear or colored which may be attached to the side member portions of the frame so that as the frame is moved back and forth the side portion is expanded or folded in accordance to the relative position of adjacent frames. The side 71 may be continued upwardly or a different top covering 72 may be supplied so as to extend from the outermost frame to the wall. In FIG. 1 the cover extends from the rightward frame 66 to the leftward frame 60 when the framework is expanded to its maximum position. The ends of the structure as provided by the frame 60 may be covered by a screen or plastic wall 75 with selected supports and also a framework which may include a door 76.

Referring particularly to FIGS. 3 and 4, it is to be noted that as the frame is moved leftwardly the portions of the four cables to the left of the frame, of course, becomes shorter as the frame moves on those cables and those portions of cables to the right of the frame become longer as the frame moves leftwardly. However, as the distance from the pulleys 16 down to the lower pulleys 34, 40, 46 and 52 are fixed and always the same, it is apparent that as the frame is moved the cables maintain the frame in the position in which it was originally erected. As each frame is pushed forwardly or backwardly it maintains its erected alignment without restraint as it is moved to the desired position or until the outer sides 71 and top or roof 72 which are attached to the frames limits and determines the extent of the movement of the several frames.

Use and operation of the preferred embodiment

The structure above-described may be an independent canopy or may be used in conjunction with a permanent structure such as a house and the like. When used with a house it is only necessary that the position and extent of the enclosure be determined and against the house the frame 66 is attached. The forward or outward extent of the structure is determined, at which point the post 20 is erected. When it is desired that the structure be self-supporting and independent of any other structure, as for example, as a swimming pool cover and the like, then the post 21 is also erected which provides the other determined extent of the structure. Normal to the axis between the two posts is the determined positions for the attaching of the ends of the cables as indicated by points 48, 54, 42 and 36. Having located these points the cables 24, 26, 28 and 30 are attached to the top of the posts and from these posts are fed to and threaded through the frame. The frame is placed in a desired established position, preferably vertical, and the other ends of the cables are attached so that the cables are brought into and maintained with a predetermined amount of tension.

It is to be noted, of course, that the plate 14 need not be exactly at the apex of the frame but may be slightly below that so that the cables are disposed on the underside of the frame without interference or engagement of the structure of other frames.

It is also, of course, to be noted that the pulleys 16 may all be mounted upon a common shaft or axle with a cable

being brought directly to and around each pulley. The pulleys 16 may be mounted upon two shafts with the shafts lying in a plane at right angles to the plane of the posts. This arrangement is described as an alternate embodiment below.

When the structure is rather extensive, the tension in the cables may be maintained by means of a spring and the like; also, the cable may be tensioned by means of a turnbuckle or other means. The tensioning of the cable although important is not considered a novel feature of this structure as cable tensioning devices are quite common.

Alternate embodiment of cable and frame

In FIGS. 5 through 8 there is shown an alternate means of assembly and construction of the frame and cables contemplated for use in this invention.

Referring now in particular to FIGS. 5 and 6, it is to be noted that the frame member 12 is a U-shaped or box extrusion and, at its apex, instead of a plate 14 there is provided a headed pin 80 carrying on an intermediate portion thereof a roller 82. This roller is adapted to retain and to receive the cables and rotate with the movement of the frame. FIG. 6 shows the roller as seen carrying cables 26 and 30 with the roller 82 rotating as the member 12 is moved back and forth. The cables are carried by and are redirected over the roller 82 and since both cables are moved in the same direction, the roller 82 carries both of them for movement of the cables at the same speed. In like manner a similar roller and pin is mounted adjacent to the roller assembly shown in FIG. 6 and, as seen in FIG. 5, carries the cables 24 and 28 and when of the same size and is rotated at the same speed as the roller 82. In FIG. 6 and for purposes of identification, the rightwardly illustrated pin is 84 and the roller is 85.

Referring particularly to FIG. 6, it is to be noted that the U-shaped structure 12 has passageways 87 and 88 formed therein for the passage therethrough of the cables. The inner or bottom side of the U-shaped frame 12 is provided with a closing or covering plate 89 having upright portions 90 and 91 attached so as to provide slots 92 and 93 for the insertion therethrough of film or flexible screen members 94 and 95. These members have the ends thereof fastened to or formed into tubular portions 96 and 97 so that when mounted in the slots 92 and 93, the film or flexible screens 94 and 95 is firmly retained therein. As thus arranged with the members 94 and 95 on the inner portion of the frame the cables pass above or outside the members 94 and 95 without engagement or damage to them.

It is also to be noted, of course, that the outwardly extending cable portions may be carried and guided in the interior portions of the structure 12 and between the portions 90 and 91 and as guided thereby they move downwardly to the outward and bottom portion of the frame more fully shown and described in conjunction with FIGS. 7 and 8.

Referring now in particular to FIGS. 7 and 8, wherein the cables, as for example, 26 and 30 are brought downwardly to the end of the frame 12 at which point a channel member 100 which is similar to frame 12 is laid upon or in the ground, this channel 100 provides a trackway for lateral retention of the frame during the movement of the frame 12. This frame has attached to its inner lower portion a block 102 carrying a shaft 104. This shaft rotatably carries thereon a roller 106 around which is guided and carried the cables 26 and 30.

Referring now in particular to FIG. 7, it is to be noted that as the frame 12 is moved to and fro as indicated by the arrows, the cables 26 and 30 as redirected by means of roller 106 moves around the roller to maintain the ends of and the channel 12 itself in an erected and substantially vertically predetermined position. Of course, the closing plate member 89 may be continued all the way to

the ends of the member 12 and the flexible members 94 and 95 also may be continued down member 12 to the bottom end adjacent the channel member 100. The members 94, 95, 90, 91, 96 and 97 which would therefore be seen in FIG. 8 has been omitted in this figure for clarity of illustration. In this manner as the frames are moved to the expanded or closed position the flexible members 94 and 95 retain their position in respect to the ground and to the movable frames.

Referring finally to FIG. 9, there is shown a line outline of an arch or support frame of an alternate shape in which two upright side portion members 112 are substantially parallel to each other and from their upper ends the side members are bent to form or are attached to sloped rafter portion members 113 which terminate or join at an apex 114. The cross-section of this alternate frame may be like the assembly of FIG. 6 with aluminum extrusions providing the structural components of the frame. Other shapes of frames, of course, may be provided, it being only necessary that they be provided with cable and pulley arrangements providing a Z-cable arrangement for four cables as shown in FIG. 4. When desired for stability and/or because the arch is of a large size additional cables arranged in a Z-pattern may be provided. A pair of additional cables, for example, might be provided at the juncture of sides 112 and rafters 113 in FIG. 9.

It is readily seen that the structure constructions as above-described are economically practical and high production can be made and maintained, that the parts can be prefabricated for ready assembly and that replacement and repair is easily provided for. The cables as contemplated for use in this structure are of the aircraft flexible metal type such as stainless steel. These cables are approximately one-eighth inches in diameter and when of stainless steel have sufficient tensile strength to retain the movable members in the preselected erected arrangement and that these members are maintained in parallelism as they are pushed to and fro at the selection or discretion of the owner or user.

Although each member requires four cables to maintain its alignment, the cost of the cables and the space required for the cables moving within a frame which may, for example, be two inches square and is preferably made of extruded aluminum provides a strong yet light weight member which may be used as a support for a swimming pool cover, as a canopy or enclosure for a patio or in an abbreviated vertical height may be used as a truck cover which may be moved to the cab or towards the end of the truck as desired.

It is, of course, to be noted that as described there is provided a structure adapted for covering patios or swimming pools, which structure, of course, permits the pushing of all of the frames to one end so that the patio or swimming pool may be exposed to the natural elements. Of course, it is quite relevant that the structure be movable into an open or closed position any time that it is desired and that the material forming the walls and roof of the enclosure be a type of material which is highly flexible. However it is contemplated that removable panels may be attached to these frames if desired. These frames may also have substantially rigid panels which are arranged to telescope within one another when closed and which join with adjacent panels to provide a substantially rigid wall when expanded.

It is, of course, realized that this type of structure may be used to provide an expandable cover for trucks, in which case instead of the ground as indicated in FIG. 1, the platform or sides of the truck body may be determined as being the ground level and the vertical side extents of the frame members 12 may be made whatever length is desired and also, of course, the roof may be an arc or sloped and may be any pitch from a substantially flat roof to a slope of any desired pitch, this being merely a matter of selection.

It is to be further noted that posts 20 and 21 need not be fixedly erected in the ground and the like but instead may be erected in the manner of a tent pole. When so erected the posts have their bottom ends resting in either temporary or permanent sockets. The upper ends of the posts are maintained in the desired erected position by means of ropes or cables attached to the posts so as to accommodate the overturning forces on the posts and retain the posts upright. Other obvious equivalents may be used to support or replace the posts and it is to be pointed out that the posts are intended only to support and retain the upper ends of the cables with no novelty ascribed to the method of erecting and supporting the posts.

Method of arranging the cables

The structure of this invention provides for a method of arranging the plurality of cables used with each frame so that each cable is disposed in a generally X-form and so that the apex and outer ends of each frame is supported and retained as erected and the frame is movable in a path normal to the plane of the member, the method of arranging the cables including retaining one end of a cable to a fixed support such as a post or building, the attached end of the cable disposed in a fixed position in a plane substantially midway of the ends of the frame and at a height generally the same as the midportion of the erected frame; feeding or extending a first length of cable downstream of the retained end and toward the other limit of the structure, the first length of cable extending to a first pulley or guide mounted midway of the ends of the frame and with the general axis of the first length of cable being generally normal to the plane of the frame; leading or guiding a second length of cable from the first pulley or guide to a second pulley or guide mounted on the frame and near the outer bottom end of the the frame; guiding the cable around the second pulley and feeding a third length portion of cable from the second pulley to a fixed position further downstream of the erected frame, the third length of cable being generally parallel to the first length of cable, and attaching and tensioning the other end of the cable to a fixed post or position on a building, the attached end being at the same height generally as the end of the erected frame. In addition there is provided the step of guiding and retaining the ends of the frame so as to limit the lateral movement of the frame from the axis of the adjusting movement.

Terms such as "in", "out", "downstream", "normal" and the like are applied to the extensible canopy structure as shown and described in conjunction with the drawings. These terms are used merely for the purposes of description and do not necessarily apply to a particular position in which the structure may be constructed or used.

The conception of the extensible canopy structure and the method of arranging the cables and its many applications is not limited to the examples above-described but departures therefrom may be made within the scope of the accompanying claims and protection is sought to the broadest extent the prior art allows.

What is claimed is:

1. An extensible canopy structure for the movable covering and uncovering of patios, swimming pools and the like, the structure having at least one frame independently movable between two fixed support positions, the canopy structure comprising: (a) at least one frame of generally planer construction and providing outer end portions adapted to support the frame; (b) a cable guide and the like midway between the ends of the frame and adapted to receive and redirect at least four cables; (c) a cable guide and the like near the end of the frame and adapted to receive and redirect at least two cables; (d) four cable lengths adapted to engage the cable guides of the frame and support the frame in an erected position while permitting the frame to be moved in a direction normal to the frame in said erected position, and (e)

fixed support positions for attaching the ends of the cable, said positions determining the longitudinal extent of the expanded structure, each of said cables being attached at one first end to a first fixed support position and extending upstream from this position and normal to the plane of the frame, the cable continuing to the frame and to and around one of the midway cable guides thence to and around one of the cable guides near the end of the frame thence extending further upstream and normal to the plane of the frame to a second fixed support position where the second end of the cable is attached.

2. An extensible canopy structure as in claim 1 in which the cable guides are pulleys, rollers and the like and are freely rotatable on shafts and the like.

3. An extensive canopy structure as in claim 2 in which the pulleys midway between the ends of the frame are mounted on two shafts arranged to lie in the plane of the frame.

4. An extensible canopy structure as in claim 2 in which the pulleys midway between the ends of the frame are each carried on a pin mounted in a plate.

5. An extensible canopy structure as in claim 2 in which a single shaft is provided near each end of the frame so as to support a pulley for guiding the cables extending from the end of the frame.

6. An extensible canopy structure as in claim 1 in which the movable frame is a U-channel in cross-section and with a cover plate adapted for attaching to and closing the open side of the U-channel.

7. An extensible canopy structure as in claim 6 in which the cover plate is provided with a retaining means for receiving the edge of and retaining a sheet of film, cloth, screening and the like.

8. An extensible canopy structure as in claim 1 in which there is a multiplicity of frames each independently movable and each supported and maintained in its erected alignment by at least four cable portions each arranged in a Z-pattern.

9. An extensible canopy structure as in claim 8 in which the frame is formed with side portions substantially parallel to each other and with a rafter portion attached to and extending inwardly and upwardly from the upper ends of the side portions, the rafter portions joining at an apex.

10. An extensible canopy structure as in claim 1 in which the frame is a U-channel in cross-section and with a pair of pins attached to the channel frame at its apex, each pin carrying a roller adapted to receive and redirect two of the cables, each approaching the frame from opposite fixed support positions, and with a shaft carried near the bottom end of the frame and carrying a roller adapted to receive the cables redirected from the apex roller and to redirect these cables to opposite fixed support positions.

11. An extensible canopy structure as in claim 10 in which the U-channel is disposed with its open side toward the inside of the frame, the channel provided with a cover plate adapted to close the open inner side of the U-channel while providing receiving and retaining means for the edge of a sheet of film, cloth, screening and the like.

12. An extensible canopy structure as in claim 11 in which there is provided a U-channel adapted to lie on a support surface which may be the ground level, the channel adapted to engage a guide means on the frame and support the end of the frame to prevent transverse movement of the frame as it moved longitudinally along the U-channel.

13. In an extensible canopy structure the method of supporting a frame member of generally planer construction, the frame member movable in a position as erected and generally in a path normal to the plane of the member, the method of arranging each cable portion of four cables for supporting the frame, the steps including: (a) retaining one end of a cable to a fixed position and in a

plane substantially midway of the ends of the frame and at a height generally the same as the midportion of the erected frame; (b) feeding a first length of cable downstream of the retained end of the cable and to a first pulley mounted midway of the ends of the frame, said first length of cable being disposed generally normal to the plane of the frame; (c) leading a second length of cable from the first pulley to a second pulley mounted near one end of the frame; (d) feeding a third length of cable from the second pulley to a fixed position and further downstream of the erected frame, the third length being generally parallel to the first length of cable, and (e) attaching and tensioning the other end of the cable to a fixed position, the attached end being at the same height generally as the end of the erected frame.

14. In an extensible canopy structure the method of claim 13 in which there is additionally provided a plurality of frames each independently movable and including the step of connecting each frame to an adjacent frame by means of a film, screen and the like.

15. In an extensible canopy structure the method of claim 14 in which there is additionally provided a pair of U-channels adapted to lie on a support surface, the channels sized and spaced from engaging and guiding the ends of the frame to prevent transverse movement of the frame during the longitudinal manipulation and movement of the frame.

References Cited

UNITED STATES PATENTS

2,187,436	1/1940	Thofehrn et al.	-----	135—1
2,603,171	7/1952	Smith	-----	52—66
2,796,072	6/1957	Smith	-----	135—5

KENNETH DOWNEY, *Primary Examiner.*

U.S. Cl. X.R.

135—3, 5, 7.1; 52—63, 64, 66; 4—172